

ALTAN KALDIRMA TELESKOPIK SİLİNDİR

UNDERBODY TIPPING TELESCOPIC CYLINDER

www.ozceylanlar.com.tr

UCB/1320/3205/5

2216616013205



ÖZELLİKLER / SPECIFICATIONS

Maksimum Çalışma Basıncı / Maximum Working Pressure	190 bar
Toplam Yağ Hacmi / Total Oil Volume	18 lt
Silindir Ağırlığı / Cylinder Weight	115 kg
1. Kademe Maksimum İtme Kuvveti (180 bar)	39 ton
Maximum Thrust First Stage (180 bar)	
Toplam Strok / Total Stroke	1320 mm
Yağ Giriş Çapı / Oil Inlet Diameter	M27x1,5
Hidrolik Yağ Sıcaklığı / Oil Temperature Range	-20 & 80 °C
Kapalı Boy / Closed Length	490 mm
Açık Boy / Open Length	1810 mm

KADEME TABLOSU / REFERENCES

Kademe / Extension	1	2	3	4	5	6	7
Çap / Diameter	160	135	115	95	75		

TEKNİK ÇİZİM / TECHNICAL DRAWING

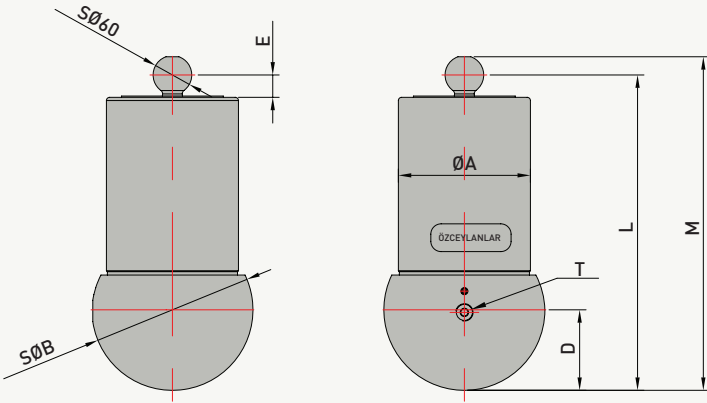

REFERANSLAR / REFERENCES

A	:	205 mm
B	:	250 mm
C	:	
D	:	125 mm
E	:	35 mm
F	:	
G	:	
H	:	
I	:	
J	:	
K	:	
L	:	490 mm
M	:	520 mm
N	:	
O	:	
P	:	
R	:	
S	:	
T	:	M27x1,5

KARŞILAŞTIRMA TABLOSU / COMPARISON TABLE

Strok CT 1320 mm	Kalkma Açısı α° / Body Tilting Angle α°				
	40	45	50	55	60
Bağlantı Mesafesi / Pivot Length DP (mm)	1930	1725	1562	1429	1320

