

ÖNDEN KALDIRMA TELESKOPIK SİLİNDİR

FRONT TYPE TELESCOPIC CYLINDER

www.ozceylanlar.com.tr

FE/5700/1245/5

2215121257005

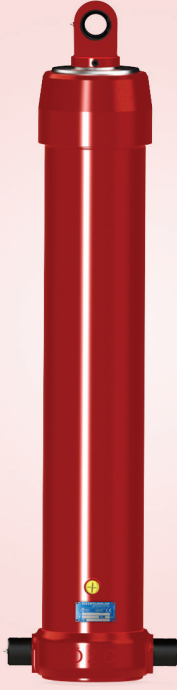

ÖZELLİKLER / SPECIFICATIONS

Maksimum Çalışma Basıncı / Maximum Working Pressure	190 bar
Toplam Yağ Hacmi / Total Oil Volume	136 lt
Silindir Ağırlığı / Cylinder Weight	390 kg
1. Kademe Maksimum İtme Kuvveti (180 bar) Maximum Thrust First Stage (180 bar)	69 ton
Toplam Strok / Total Stroke	5400 mm
Yağ Giriş Çapı / Oil Inlet Diameter	R 3/4"
Hidrolik Yağ Sıcaklığı / Oil Temperature Range	-20 & 80 °C
Kapalı Boy / Closed Length	1390 mm
Açık Boy / Open Length	6790 mm

KADEME TABLOSU / REFERENCES

Kademe / Extension	1	2	3	4	5	6	7
Çap / Diameter	212	185	160	135	115		

TEKNİK ÇİZİM / TECHNICAL DRAWING

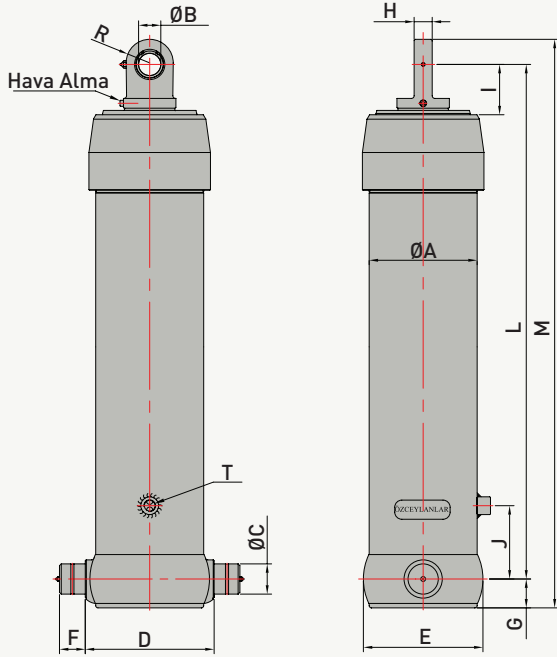

REFERANSLAR / REFERENCES

A	:	243 mm
B	:	50 mm
C	:	68 mm
D	:	290 mm
E	:	285 mm
F	:	58 mm
G	:	65 mm
H	:	40 mm
I	:	100 mm
J	:	165 mm
K	:	
L	:	1390 mm
M	:	1510 mm
N	:	
O	:	
P	:	
R	:	55 mm
S	:	
T	:	R 3/4"

KARŞILAŞTIRMA TABLOSU / COMPARISON TABLE

Strok CT 5400 mm	Kalkma Açısı α° / Body Tilting Angle α°				
	40	45	50	55	60
Bağlantı Mesafesi / Pivot Length DP (mm)	7894	7055	6389	5847	5400

