

ALTAN KALDIRMA TELESKOPIK SİLİNDİR

UNDERBODY TIPPING TELESCOPIC CYLINDER

www.ozceylanlar.com.tr

UCB/1650/3175/5-3

2216513516505



ÖZELLİKLER / SPECIFICATIONS

Maksimum Çalışma Basıncı / Maximum Working Pressure	190 bar
Toplam Yağ Hacmi / Total Oil Volume	15 lt
Silindir Ağırlığı / Cylinder Weight	87 kg
1. Kademe Maksimum İtme Kuvveti (180 bar)	28 ton
Maximum Thrust First Stage (180 bar)	
Toplam Strok / Total Stroke	1560 mm
Yağ Giriş Çapı / Oil Inlet Diameter	M22x1,5
Hidrolik Yağ Sıcaklığı / Oil Temperature Range	-20 & 80 °C
Kapalı Boy / Closed Length	560 mm
Açık Boy / Open Length	2120 mm

KADEME TABLOSU / REFERENCES

Kademe / Extension	1	2	3	4	5	6	7
Çap / Diameter	135	115	95	75	55		

TEKNİK ÇİZİM / TECHNICAL DRAWING

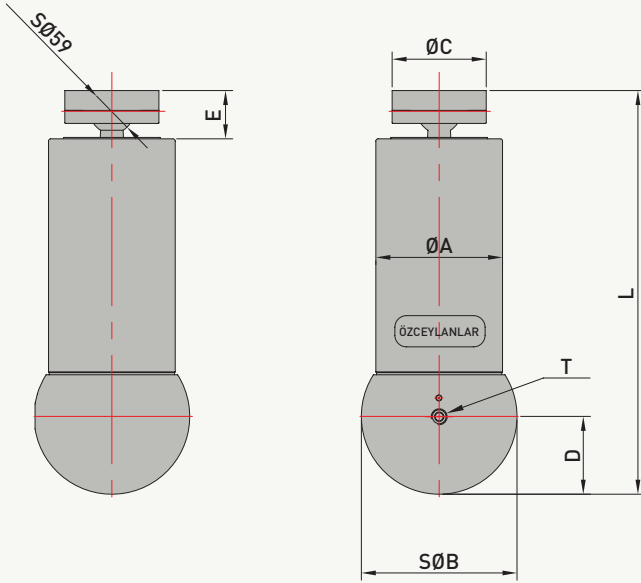

REFERANSLAR / REFERENCES

A	:	175 mm
B	:	215 mm
C	:	130 mm
D	:	107,5 mm
E	:	67 mm
F	:	
G	:	
H	:	
I	:	
J	:	
K	:	
L	:	560 mm
M	:	
N	:	
O	:	
P	:	
R	:	
S	:	
T	:	M22x1,5

KARŞILAŞTIRMA TABLOSU / COMPARISON TABLE

Strok CT 1560 mm	Kalkma Açısı α° / Body Tilting Angle α°				
	40	45	50	55	60
Bağlantı Mesafesi / Pivot Length DP (mm)	2281	2038	1846	1689	1560

